

## SPECIFICATION SHEET

### ZD-XXXX RECTANGULAR, MOTORIZED CONTROL DAMPERS

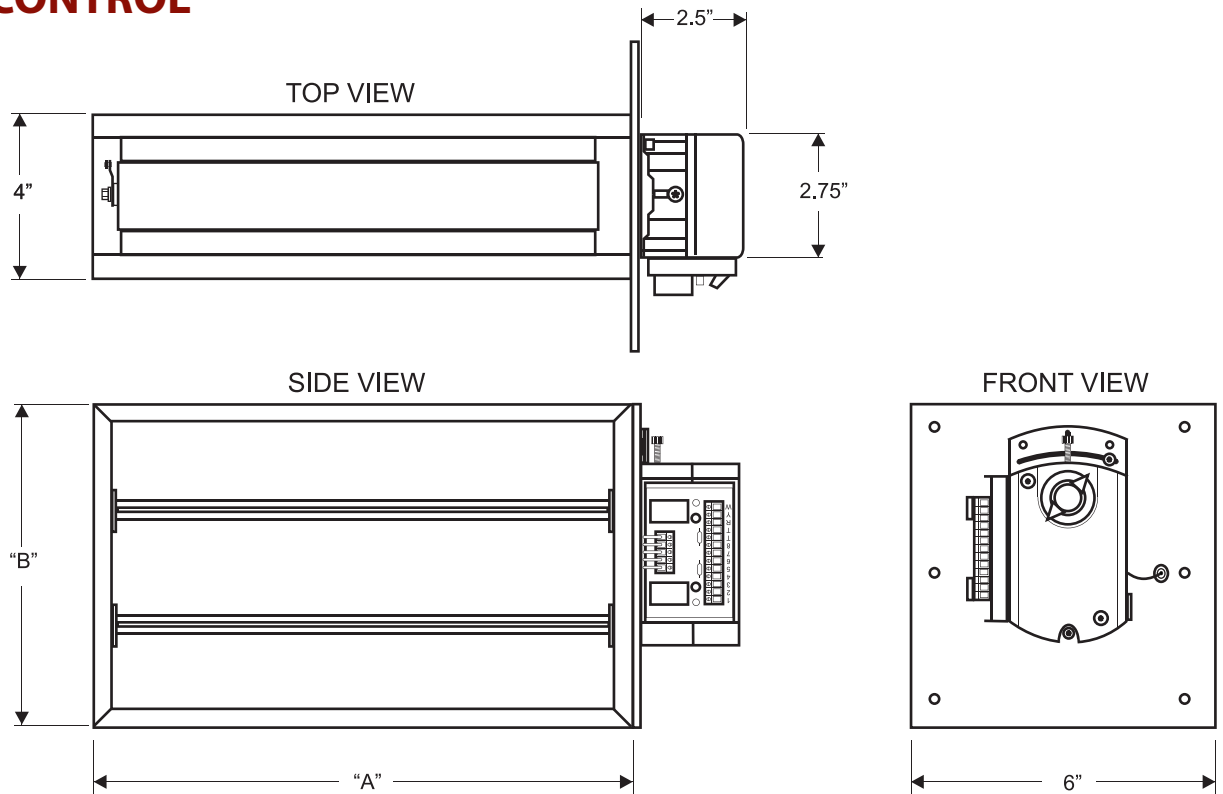

#### DIMENSIONS:

Damper models ZD-XXXX are sized width (A) by height (B) with actuator on the (B) dimension.  
 Bottom mount models ZD-XXXX-BM are sized width (A) by height (B) with actuator on the (A) dimension.  
 Actual (A) and (B) dimensions are undercut 1/4".  
 Standard sizes range from 8" x 8" up to 36" x 24" in 2" increments.

#### APPLICATION:

For Zone One stand along modulating and Z-1600 modulating zone control systems with static pressures less than 1.0" w.c.  
 Requires Z-1600-T P+I control thermostat.

#### CONSTRUCTION:

- 1/16" extruded aluminum frame
- 1/16" extruded aluminum parallel blades
- 1/16" aluminum mounting flange
- Nylon bushings
- Minimum position adjustment

#### ELECTRICAL:

- 24 Volt, 2 VA, floating point
- 90 second timing
- 44 lb.-in
- Factory mounted PC actuator board and duct sensor