

Comfort System™

Wiring Diagram For Z-300-HC-MS Multi-Stage Heat / Cool Zone Control Panel Auto Changeover - Cooling Priority

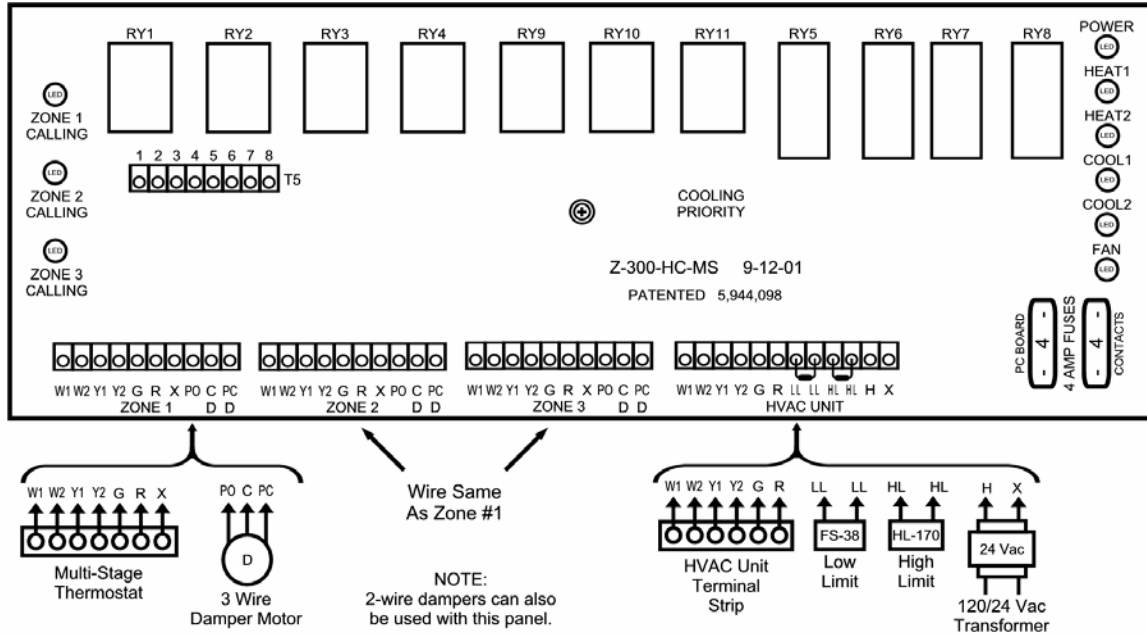

Red LEDs indicate system status. Fan LED indicates when a thermostat is calling for the fan.

When green zone LEDs are on, those zones are calling for heating or cooling.

Installation Notes:

To install the panel, first slide the PC board out of its base and screw the base to a flat surface next to the HVAC equipment. The PC board should be reinstalled by centering it over the base and pushing firmly.

Connect only 24 Vac to Control Panel

The control panel requires a separate 24 Volt transformer.

No special wire is required.

The thermostats and motorized dampers may be located up to 300 feet from the control panel when using 18 gauge thermostat wire.

The right fuse (4 Amp) protects the relay contacts. The left fuse (4 Amp) protects the printed circuit board.

If condensing unit is not equipped with short cycle protection, a short cycle protection timer (TD-5) should be installed.

For split systems, the wires from the condensing unit should be connected to the appropriate terminals at the furnace.

The low limit (FS-38) should be wired to the "LL" terminals on the panel (remove jumper). The compressor will shut off when low limit trips out.

The high limit (HL-170) should be wired to the "HL" terminals on the panel (remove jumper). The furnace will shut off when high limit trips out.

For Powered Closed / Spring Return Open Dampers (2-wire):

A 40 VA transformer will power the panel and up to four (4) dampers.

A 75 VA transformer will power the panel and up to seven (7) dampers.

Up to three (3) dampers can be connected in parallel. A total of no more than seven (7) dampers may be connected to the system. A system may be a single panel or multiple panels.

For Powered Closed / Powered Open Dampers (3-wire):

Panel and transformer capacities will vary depending on damper actuator used.

If more than three (3) zones are required, two additional panels can be used to control up to a total of nine (9) zones. T5 terminal strip is used only when more than three zones are required.

Label the dampers, damper wires and thermostat wires with the zone number and the area they serve.

Specifications:

Panel Dimensions:

Height: 5.0 inches

Width: 11.0 inches

Depth: 2.0 inches

Mounting:

2 back plate screws

Operating Ambient

Temperature: -20° to 160° F

Power Supply:

24 Vac 40VA / 75VA transformer

Terminal Designations:

W1 = 1st Stage Heat

W2 = 2nd Stage Heat

Y1 = 1st Stage Cool

Y2 = 2nd Stage Cool

G = Fan

R = Hot 24 Volt

X = Common

PO = Powered Open

C (D) = Common (Damper)

PC (D) = Powered Closed

LL = Freeze Stat

HL = High Limit

H = Hot 24 Volt

X = Ground or

Common

Jackson
SYSTEMS

11-17-03

Website: www.jacksonsystems.com
E-mail: info@jacksonsystems.com

5418 Elmwood Avenue
Indianapolis, IN 46203

Toll-Free: 888.652.9663
Fax: 317.227.1034

Comfort System™

Z-300-HC-MS Multi-Stage Heat / Cool Zone Control Panel

Sequence Of Operation

Comfort System™ is a commercial zone control system that allows a single HVAC unit to have up to three separate zones (nine if three panels are connected together). Each zone is controlled by its own space thermostat and motorized zone damper. If any of the zone thermostats call for heating or cooling, the zones not calling will have their dampers powered closed, and the zone(s) calling will have its (their) damper(s) remain open. The heating or cooling equipment will also be brought on at the same time. When all zone thermostats are satisfied, the heating or cooling equipment turns off and all zone dampers return to the open position to allow for continuous air circulation.

If one of the zone thermostats is calling for heating and another zone thermostat is calling for cooling, the one calling for cooling will take priority and the system will operate in the cooling mode. When the thermostat that is calling for cooling is satisfied, the system will change over and take care of the heating requirement. This is referred to as “Auto Changeover - Cooling Priority.”

Thermostats

The zone control system works with multi-stage or single-stage heat / cool thermostats. The thermostats can be either manual or auto changeover.

Typical System

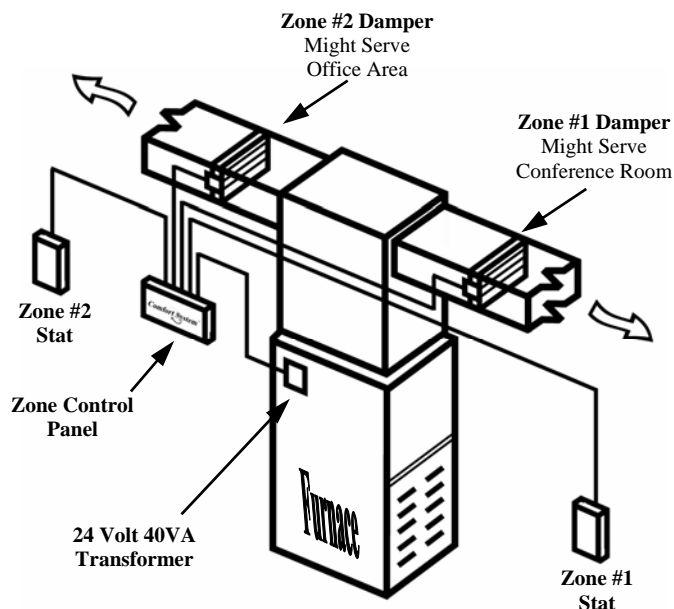

System Checkout

Verify that all wires have been connected to the proper terminals and are secure.

Verify that the jumpers across the “LL” and “HL” terminals were removed before connecting the high and low limit stats.

The low limit (FS-38) should be wired to the “LL” terminals on the zone control panel. The high limit (HL-170) should be wired to the “HL” terminals on the zone control panel.

Zone dampers can be either 3-wire (powered closed / powered open) or 2-wire (powered closed / spring return open).

- 3-wire dampers use PO, C and PC.
- 2-wire dampers use C and PC.

When a green zone LED is on, that zone is calling for heating or cooling.

To check the system for proper operation, pull the disconnect for the condensing unit to prevent short cycling. Next, place all the zone thermostat mode switches in heat mode and turn down all thermostat set points. Go to each zone thermostat, one at a time, and call for heat to verify that the proper zone dampers are open (and the rest are closed). Turn the zone thermostat back down before checking the next zone.

Jackson
SYSTEMS

11-17-03

Website: www.jacksonsystems.com
E-mail: info@jacksonsystems.com

5418 Elmwood Avenue
Indianapolis, IN 46203

Toll-Free: 888.652.9663
Fax: 317.227.1034